

Warning

Do not install unit in draughty conditions where the air movement is greater than 0.2mtr/sec.
 e.g. near entrance/exit doors, open windows, under air conditioning units or a ceiling mounted fan
 Ambient room conditions must not drop below 16°C.
 Ticket strips must be in place on each shelf and the front tray must not be removed



Versigen Specification

Heated Display

Recirculated forced air system
 LED Illumination
 with internal adjustable shelving
 ticket strips and front tray and
 rear sliding double glazed doors

Capacity

0.20 m3

Dimensions

Width - 1158mm
 Depth - 660mm
 Height - 816mm
 Weight - 90kg

Power Rating

2.5kw
 complete with a 2m long cord set & 15amp plug

Materials

1.2mm 304 Grade St/ Steel Top & Supports
 0.7mm 430 Grade St/ Steel Internal Structure
 6mm Tempered Glass

Installation

Counter Top Flush Fit Cut Out Dimensions
 1164mm x 666mm x 25mm
 Counter Support Cut Out Dimensions
 1140mm x 642mm

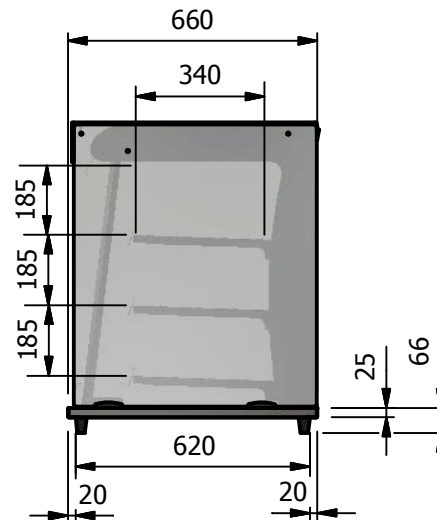
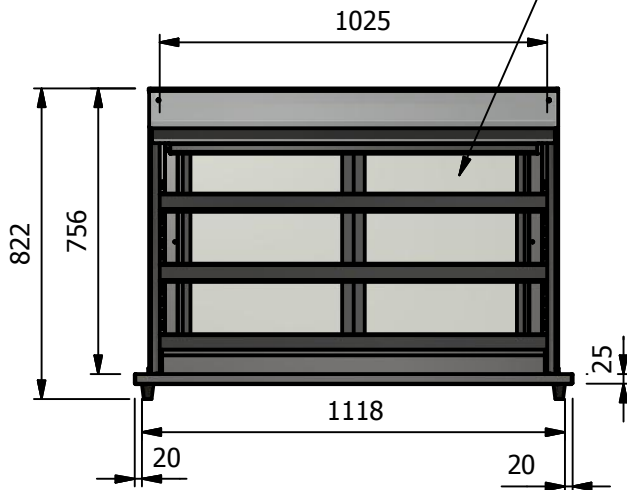

ALL SHEET METAL DIMENSIONS ARE I/S (INSIDE SIZES) (UNLESS OTHERWISE STATED)

ALL DIMENSIONS IN (mm), TOLERANCE = LINEAR ± 0.5mm, ANGULAR ± 0.5mm (OR AS STATED). ALL SHARP EDGES TO BE REMOVED FROM SHEET METAL PARTS

Product	GRAB & GO'S			Product No			
Description	D3GHSL			<small>© No reproduction or publication of this drawing may be made, and no article may be manufactured or assembled in accordance with this drawing without prior written consent. This prohibition is a term of any contract relating to this drawing. Rights reserved under the Copyright Act 1956 as amended by the Design Copyright Act 1968.</small>			
Material/Finish	Thickness		Desp/Date				
Legacy P/N	Weight	90kg	Quote No.	Dwg No.	GGP-028548	Issue	
Client			SO Number	N/A	Drawn By	ABB	-
Client Project			Approved By		Date	26/02/2019	
VERSIGEN AUSTRALIA PTY LTD, 182 HARTLEY ROAD, SMEATON GRANGE, NSW 2567, T: +61 (0)131 653 330, E: sales@versigen.com.au, Web: www.versigen.com.au					Scale	1:20	Sheet 1 / 2 A4