

NOTE:- Serving height for children up to 12 years of age.
 This model is available with a work top height of 800mm
 and a Trayslide height of 773mm.
 Please add "B" to the end of the product code.

Specification

Neo-Ceram glass hot Top
 The Stainless steel top inset with Neo Ceram
 glass panels provides a clean hot serving area.

Dry Heat
 Fan Assisted Hotcupboard

Dimensions
 Width - 1158mm
 Depth - 680mm
 Height - 900mm
 Weight - 82kg

Area of hot top
 989mm x 537mm

Capacity of Hot Cupboard [usable inside space]
 Width - 1023mm
 Depth - 555mm
 Usable Height Bottom shelf - 204mm
 Usable Height Top Shelf - 245mm

35 covers & meals [10" plated meals stacked using plate covers]
 or
 133 off 10" plates stacked for heating
 or
 6 off 1/1GN pans side by side 150mm deep 3 on top 3 on bottom

Power Rating
 2.04kw with no gantry, 2.48Kw with heated gantry.
 complete with a 2m long cord set & 15 amp plug
 Removable Fan heating System Sahara Fan Model SF315

Materials
 1.2mm 304 Grade St/ Steel Top & Supports
 0.7mm 430 Grade St/ Steel Internal Structure
 GN 1/1 Grid Shelves with 30mm x 30mm tube supports

Installation
 All swivel castors, two braked



Sahara Fan Model SF315

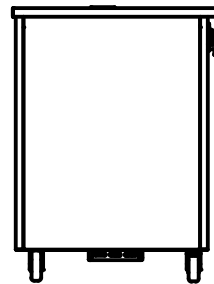
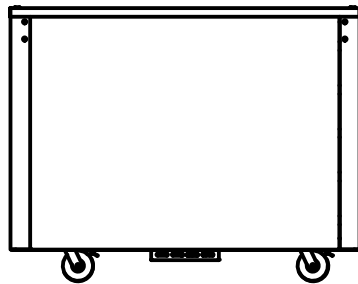
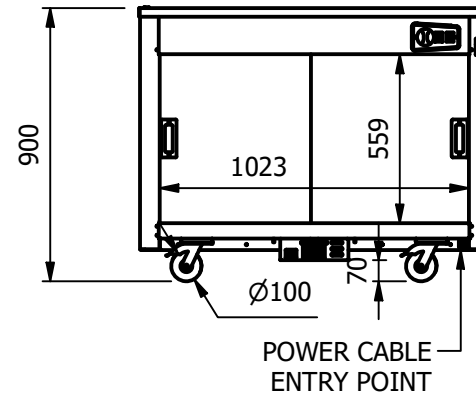
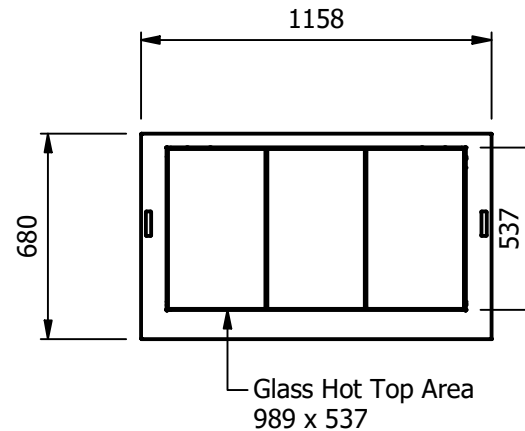

ALL SHEET METAL DIMENSIONS ARE I/S (INSIDE SIZES) (UNLESS OTHERWISE STATED)

ALL DIMENSIONS IN (mm), TOLERANCE = LINEAR ± 0.5mm, ANGULAR ± 0.5mm (OR AS STATED). ALL SHARP EDGES TO BE REMOVED FROM SHEET METAL PARTS

Product	VERSCARTE			Product No	N/A			 <p>No reproduction or publication of this drawing may be made, and no article may be manufactured or assembled in accordance with this drawing without prior written consent. This prohibition is a term of any contract relating to this drawing. Rights reserved under the Copyright Act 1956 as amended by the Design Copyright Act 1968.</p>	
Description	VC3HT			Desp/Date					
Material/Finish	Thickness			Quote No.		Dwg No.	VCP-072582	Issue	
Legacy P/N	Weight	82kg		SO Number	STANDARD	Drawn By	ABB	-	
Client				Approved By		Date	28/10/2019		
Client Project						Scale	1 : 25	Sheet	
VERSIGEN AUSTRALIA PTY LTD, 182 HARTLEY ROAD, SMEATON GRANGE, NSW 2567, T: +61 (0)131 653 330, E: sales@versigen.com.au, Web: www.versigen.com.au								1 / 1	A4