

NOTE:- Serving height for children up to 12 years of age.
 This model is available with a work top height of 800mm
 and a Trayslide height of 773mm.
 Please add "B" to the end of the product code.

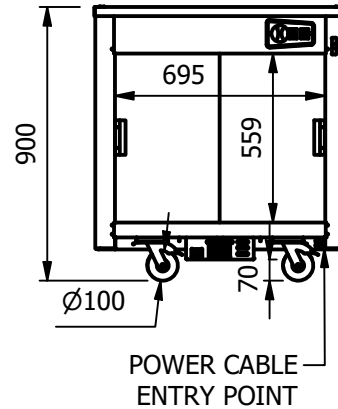
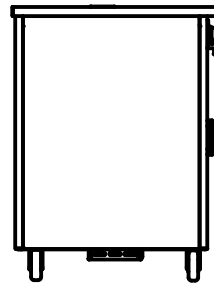
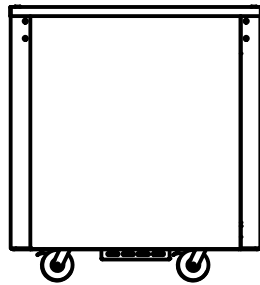
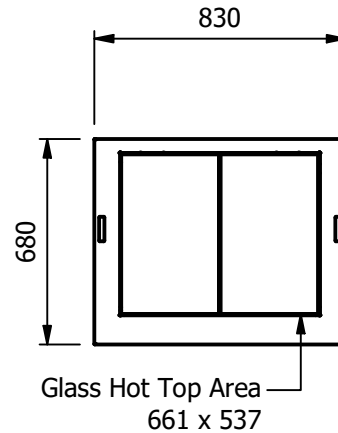

Specification

Neo-Ceram glass hot Top
 The Stainless steel top inset with Neo Ceram glass panels provides a clean hot serving area.

Dry Heat
 Fan Assisted Hotcupboard

Dimensions
 Width - 830mm
 Depth - 680mm
 Height - 900mm
 Weight - 55kg

Area of hot top
 661mm x 537mm



Sahara Fan Model SF309

Capacity of Hot Cupboard [usable inside space]
 Width - 695mm
 Depth - 555mm
 Usable Height Bottom shelf - 204mm
 Usable Height Top Shelf - 245mm

25 covers & meals [10" plated meals stacked using plate covers]
 or
 95 off 10" plates stacked for heating
 or
 4 off 1/1GN pans side by side 150mm deep 2 on top 2 on bottom

Power Rating
 1.26kw with no gantry, 1.48Kw with heated gantry.
 complete with a 2m long cord set & 10 amp plug
 Removable Fan heating System Sahara Fan Model SF309

Materials
 1.2mm 304 Grade St/ Steel Top & Supports
 0.7mm 430 Grade St/ Steel Internal Structure
 GN 1/1 Grid Shelves with 30mm x 30mm tube supports

Installation
 All swivel castors, two braked

ALL SHEET METAL DIMENSIONS ARE I/S (INSIDE SIZES) (UNLESS OTHERWISE STATED)

ALL DIMENSIONS IN (mm), TOLERANCE = LINEAR ± 0.5mm, ANGULAR ± 0.5mm (OR AS STATED). ALL SHARP EDGES TO BE REMOVED FROM SHEET METAL PARTS

| | | | | | | | | | | | |
|---|------------|------|-----------|-------------|----------|--|--|------------|-------|-------|----|
| Product | VERSICARTE | | | Product No | N/A | | | | | | |
| Description | VC2HT | | | | | | | | | | |
| Material/Finish | Thickness | | Desp/Date | | | | <small>No reproduction or publication of this drawing may be made, and no article may be manufactured or assembled in accordance with this drawing without prior written consent. This prohibition is a term of any contract relating to this drawing. Rights reserved under the Copyright Act 1956 as amended by the Design Copyright Act 1968.</small> | | | | |
| Legacy P/N | Weight | 55kg | Quote No. | | | | | | | | |
| Client | | | | SO Number | STANDARD | | Dwg No. | VCP-072492 | Issue | | |
| Client Project | | | | Approved By | | | Drawn By | ABB | - | | |
| VERSIGEN AUSTRALIA PTY LTD, 182 HARTLEY ROAD, SMEATON GRANGE, NSW 2567, T: +61 (0)131 653 330, E: sales@versigen.com.au, Web: www.versigen.com.au | | | | | | | Date | 28/10/2019 | | | |
| | | | | | | | Scale | 1 : 25 | Sheet | 1 / 1 | A4 |