



Refrigerated container for the transport of chilled and frozen products at a controlled temperature

- Available in versions:
 - AF: temperature adjustment range: from 0°C to +10°C;
 - AFH: with heating kit and temperature adjustment range: from 0°C to +40°.
- Equipped with eight guides with constant pitch (4 cm), it allows to transport different combinations with GN1 / 1 containers and submultiples.
- Insulation offered by container walls, ensures that the temperature maintenance is guaranteed with a minimum number of ignitions of the cooling unit; this contributes limiting energy consumption.
- Easy to transport by car and easy to handle thanks to the dimensions and weight content.
- Cooling unit is triggered when external temperature is higher than the temperature set with the programmable digital thermostat. This allows to maintain a constant temperature even in case of very high external temperatures.
- In the AFH versions, the heating unit is triggered when external temperature is lower than the temperature set with the programmable digital thermostat. This allows to maintain a constant temperature even in case of very low external temperatures.
- Total compliance with the cold chain at all stages of transport.
- It can be transported using conventional vehicles: it allows to simultaneously transport chilled, frozen and ambient temperature products using a single non-insulated vehicle.
- Equipped with a low consumption fridge unit.
- Dual power source: during transport can be connected to the battery (or auxiliary battery) of the vehicle and, at the destination, can be connected to mains power.
- Manufactured using the rotational moulding technology: mono-block container and door (free of sharp edges, joints and welds).
- **Fully recyclable** at the end of the operating life.

MANUFACTURING MATERIALS

Polyethylene	inner and outer walls of the container and lid; suitable for food contact	Polyurethane	insulating material between the walls of the container and of the lid; free of CFC and HCFC
Silicone	gasket	Polyamide reinforced with fiberglass	hinges
Galvanized steel	cooling unit frame	Stainless steel	latches, grip handles
(POM) acetal resin	grip handle cover		

TECHNICAL CHARACTERISTICS

TECHNICAL CHARACTERISTICS			
AF version	<ul style="list-style-type: none"> from 0°C to +10°C 	AFH version	<ul style="list-style-type: none"> from 0°C to +40°C
	Equipped with two cables: <ul style="list-style-type: none"> for power supply to 230Vac 50-60Hz. 		<ul style="list-style-type: none"> for feeding to 12/24Vdc (with cigarette lighter socket).
+/- 0,5 °C	Degree of accuracy in temperature adjustment: <ul style="list-style-type: none"> +/-0,5 °C. 		Protection against voltage drops of the vehicle battery, in case of falling below of the limit value of 11V.
GAS	Coolant gas: <ul style="list-style-type: none"> R134a 		Hermetic compressor with electronic control unit for adjustment and control equipped with overvoltage protections.
	Cooling unit performance guaranteed for use at ambient temperature: <ul style="list-style-type: none"> from +10°C to +30°C. 		Container (insulated case) guaranteed for use: <ul style="list-style-type: none"> from -30° to +100°C.
	Adjustment and control of the temperature with programmable digital thermostat.		Cooling unit equipped with a "roll-bond" static evaporator.
	Easily removable door seal.		Equipped with 8 guides with 4 cm pitch. It can carry: <ul style="list-style-type: none"> • 4GN1 / 1 H65; • 2GN1 / 1 H150; • 1GN1 / 1 H65 + 2GN1 / 1 H100; • 1GN1 / 1 H100 + 1GN1 / 1 H200.
	Equipped with opening door up to 240 ° and easily removable, to facilitate washing operations.		Melform closing hooks in stainless steel.
	Stainless steel grip handles with handle cover.		Fitted with adjustable venting valve.
	Equipped with shockproof and hinges, with high resistance to stresses.		Monobloc structure, no sharp edges, joints and welds.
	Stainless steel GN1 / 1 grid available upon request.		Insulated with CFC and HCFC-free polyurethane foam.
	Available (on request) USB datalogger to record temperature data during transport.		Smartdolly trolley: <ul style="list-style-type: none"> • loading capacity 150 kg; • 4 castors made of anti tracking rubber and PP; • castor diameter: 100 mm; • 2 fixed castors; • 2 swivelling castors. Available with chrome or ss handle.

TECHNICAL SPECIFICATIONS

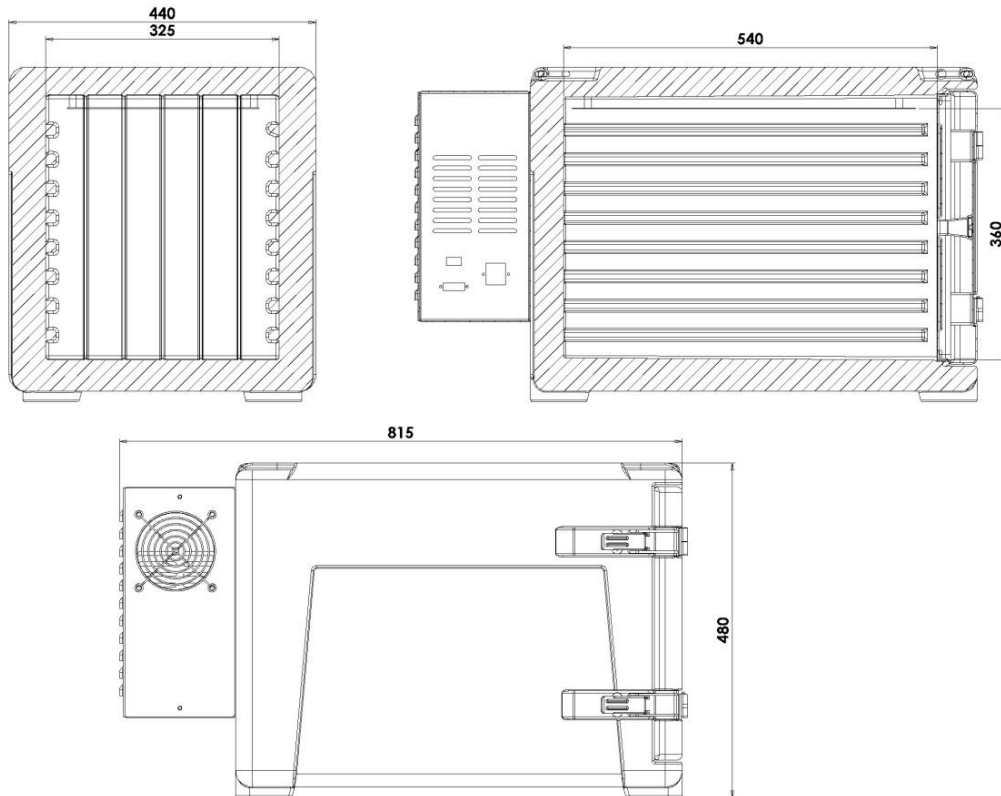

Model	Code	12V Power supply	24V Power supply	Nominal absorption	Fuses	
AF VERSION						
Koala 70 AF from 0°C to +10°C	AF089001	✓	✓	0,35A to 230Vac 3,5A to 24Vdc 7A to 12Vdc	4A for 230Vac 15A for 12/24Vdc	
AFH VERSION (with heating kit)						
Koala 70 AFH from 0°C to +40°C	AF089040	✓		0,35A to 230Vac 7A to 12Vdc	4A for 230Vac 15A for 12Vdc	
Model	Code	Colour	External dim. (mm)	Internal dim. (mm)	Capacity l	Weight Kg
Koala 70 AF/AFH cooling unit on back, static		melange grey blue	440x815xh480	325x540xh360	68	24
ACCESSORIES						
Grid GN 1/1 in stainless steel	AEA020	stainless steel	530x325xh12			1,3
Smartdolly trolley chrome handle	MAXI0019	melange grey blue	525x750xh965			9,4
Smartdolly trolley stainless steel handle	MAXI0018	melange grey blue	525x750xh965			9,4
Smartdolly trolley without handle	MAXI9007	melange grey blue	525x750x200			7