

Koala 20 AS



Refrigerated container for the transport of chilled and frozen products at a controlled temperature

- Available in versions:
 - AS: temperature adjustment range: from -18°C to +10°C;
 - ASH: with heating kit and temperature adjustment range: from -18°C to +40°.
- Insulation offered by container walls ensures that the temperature maintenance is guaranteed with a minimum number of ignitions of the cooling unit; this contributes limiting energy consumption.
- Easy to transport by car and easy to handle thanks to the dimensions and weight content.
- Cooling unit is triggered when external temperature is higher than the temperature set with the programmable digital thermostat. This allows to maintain a constant temperature even in case of very high external temperatures.
- In the ASH versions, the heating unit is triggered when external temperature is lower than the temperature set with the programmable digital thermostat. This allows to maintain a constant temperature even in case of very low external temperatures.
- Total compliance with the cold chain at all stages of transport.
- It can be transported using conventional vehicles: it allows to simultaneously transport chilled, frozen and ambient temperature products using a single non-insulated vehicle.
- Equipped with a low consumption fridge unit.
- Dual power source: during transport can be connected to the battery (or auxiliary battery) of the vehicle and, at the destination, can be connected to mains power.
- Manufactured using the rotational moulding technology: mono-block container and door (free of sharp edges, joints and welds).
- Fully recyclable at the end of the operating life.

MANUFACTURING MATERIALS

Polyethylene	inner and outer walls of the container and lid; suitable for food contact	Polyurethane	insulating material between the walls of the container and of the lid; free of CFC and HCFC
Silicone	seal	Polyamide and fiberglass	clasp
Aluminum	caster		

TECHNICAL CHARACTERISTICS

<p>AS version</p>	<ul style="list-style-type: none"> • from 0°C to +10°C • from -18°C to +10°C 	<p>ASH version</p>	<ul style="list-style-type: none"> • from 0°C to +40°C • from -18°C to +40°C
<p>+/- 0,5 °C</p>	<p>Degree of accuracy in temperature adjustment:</p> <ul style="list-style-type: none"> • +/-0,5 °C. 		<p>Protection against voltage drops of the vehicle battery, in case of falling below of the limit value of 11V.</p>
	<p>Equipped with two cables:</p> <ul style="list-style-type: none"> • for power supply to 230Vac 50-60Hz. 		<ul style="list-style-type: none"> • for feeding to 12/24Vdc (with cigarette lighter socket).
	<p>Hermetic compressor with electronic control unit for adjustment and control equipped with overvoltage protections.</p>	<p>GAS</p>	<p>Coolant gas:</p> <ul style="list-style-type: none"> • R134a
	<p>Cooling unit performance guaranteed for use at ambient temperature:</p> <ul style="list-style-type: none"> • From +10°C to +30°C. 		<p>Container (insulated case) guaranteed for use:</p> <ul style="list-style-type: none"> • from -30° to +100°C.
	<p>Adjustment and control of the temperature with programmable digital thermostat.</p>		<p>Cooling unit equipped with a "roll-bond" static evaporator.</p>
	<p>Available (on request) USB datalogger to record temperature data during transport.</p>		<p>Seal of the lid can be removed easily.</p>
	<p>Hinges integrated in the container.</p>		<p>Melform hook closure in shockproof material.</p>
	<p>Evaporator protection internal grid made of plasticised metal wire.</p>		<p>Integrated grips in the container structure.</p>
	<p>Mono-block structure, no sharp edges, joints and welds.</p>		<p>Insulated with CFC and HCFC-free polyurethane foam.</p>

TECHNICAL SPECIFICATIONS

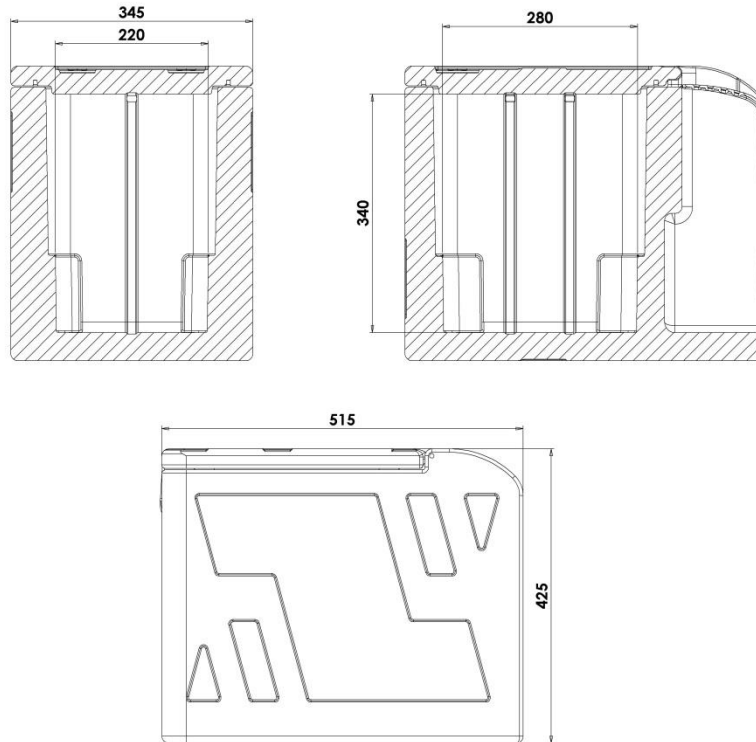

Model	Code	12V Power supply	24 V Power supply	Nominal absorption	Fuses
AS VERSION					
Koala 20 AS from 0°C to +10°C	39AC9035	✓	✓	0,35A to 230Vac 3,5A to 24Vdc 7A to 12Vdc	4A for 230Vac 15A for 12/24Vdc
Koala 20 AS from -18°C to +10°C	39AC9031	✓	✓	0,35A to 230Vac 3,5A to 24Vdc 7A to 12Vdc	4A for 230Vac 15A for 12/24Vdc
ASH VERSION (with heating kit)					
Koala 20 ASH from 0°C to +40°C	39AC9051	✓		0,35A to 230Vac 7A to 12Vdc	4A for 230Vac 15A for 12Vdc
Koala 20 ASH from -18°C to +40°C	39AC9050	✓		0,35A to 230Vac 7A to 12Vdc	4A for 230Vac 15A for 12Vdc

Model	Code	Colour	External dim. (mm)	Internal dim. (mm)	Capacity l	Weight Kg
Koala 20 AS/ASH		melange grey blue	345x515xh425	220x280xh340	21	16