

KOALA 150 AF



GN 1/1

EN

600x400

ATP



Refrigerated container for the transport of chilled and frozen products at a controlled temperature

- Available in versions:
 - AF: temperature adjustment range: from -25°C to +10°C;
 - AFH: with heating kit and temperature adjustment range: from -25°C to +40°.
- Capacious and multifunctional, thanks to the bracket and runners system, it can transport GN and EN pans / grids / trays and 600x400 mm tote boxes.
- Insulation offered by container walls ensures that the temperature maintenance is guaranteed with a minimum number of ignitions of the cooling unit; this contributes limiting energy consumption.
- Available with static cooling unit, which ensures reduced electrical consumption, or ventilated, which ensures a greater speed of achievement and temperature uniformity inside the container.
- Cooling unit is triggered when external temperature is higher than the temperature set with the programmable digital thermostat. This allows to maintain a constant temperature even in case of very high external temperatures.
- In the AFH versions, the heating unit is triggered when external temperature is lower than the temperature set with the programmable digital thermostat. This allows to maintain a constant temperature even in case of very low external temperatures.
- Total compliance with the cold chain at all stages of transport.
- It can be transported using conventional vehicles: it allows to simultaneously transport chilled, frozen and ambient temperature products using a single non-insulated vehicle.
- Dual power source: during transport can be connected to the battery (or auxiliary battery) of the vehicle and, at the destination, can be connected to mains power.
- Manufactured using the rotational moulding technology: mono-block container and door (free of sharp edges, joints and welds).
- **Fully recyclable** at the end of the operating life.

MANUFACTURING MATERIALS

Polyethylene	inner and outer walls of the container and lid; suitable for food contact	Polyurethane	insulating material between the walls of the container and of the lid; free of CFC and HCFC
Silicone	gasket	Polyamide reinforced with fiberglass	latches, hinges
Galvanized steel	cooling unit frame	Stainless steel	built-in grip handles

TECHNICAL CHARACTERISTICS

<p>AF Version</p>	<ul style="list-style-type: none"> • da 0°C a +10°C • da -18°C a +10°C • da -25°C a +10°C 	<p>AFH Version</p>	<ul style="list-style-type: none"> • da 0°C a +40°C • da -18°C a +40°C • da -25°C a +40°C
<p>+/- 0,5 °C</p>	<p>Degree of accuracy in temperature adjustment:</p> <ul style="list-style-type: none"> • +/-0,5 °C. 		<p>Protection against voltage drops of the vehicle battery, in case of falling below of the limit value of 11V.</p>
	<p>Equipped with two cables:</p> <ul style="list-style-type: none"> • for power supply to 230Vac 50-60Hz. 		<p>For feeding to 12/24Vdc</p> <ul style="list-style-type: none"> • with fork terminals for connection to the vehicle battery; • with cigarette lighter socket <p>(depending on the versions, see table in technical data for detailed information).</p>
	<p>Cooling unit performance guaranteed for use at ambient temperature:</p> <ul style="list-style-type: none"> • from +10°C to +30°C. 		<p>Container (insulated case) guaranteed for use:</p> <ul style="list-style-type: none"> • from -30° to +100°C.
<p>GAS</p>	<p>Coolant gas:</p> <ul style="list-style-type: none"> • R134a (versions cooling unit on back and on top static 0°C +10/+40°C) (versions cooling unit on back ventilated 0°C +10/+40°C) • R452A (versions -18°C +10/+40°C -25°C +10/+40°C). 		<p>Adjustment and control of the temperature with programmable digital thermostat.</p>
	<p>Available in versions static and ventilated with cooling unit on back.</p>		<p>Available in version static with cooling unit on top.</p>
	<p>Static versions equipped with a "roll-bond" static evaporator.</p> <p>Lower energy consumption compared to the version with ventilated cooling unit.</p>		<p>In ventilated versions (available with cooling unit on back) the ventilation system ensures a greater speed of achievement and temperature uniformity inside the container.</p>
	<p>USB data logger available (on request) to record temperature data during transport.</p>		<p>Hermetic compressor with electronic control unit for adjustment and control equipped with overvoltage protections.</p>

TECHNICAL CHARACTERISTICS

	<p>Fitted with an easily removable door that opens up to 240°, facilitating washing in the dishwasher.</p>		<p>Equipped with shockproof hinges, with high resistance to stresses.</p>
	<p>Easily removable door gasket.</p>		<p>Stainless steel built-in grip handles.</p>
	<p>Practical and effective closing system, composed of two closing hooks in shock-proof material and an easily removable inner door seal.</p>		<p>Fitted with adjustable venting valve.</p>
	<p>Available on request, a set of uprights and support rails for housing GN pans or grids, trays or EN grids and 600x400 mm pastry trays.</p>		<p>A stainless steel self-supporting grid for distributing the load into the container is available upon request.</p>
	<p>Trolley in polyethylene (static versions 0°C +10/+40°C):</p> <ul style="list-style-type: none"> • loading capacity 200 Kg; • 4 castors made of anti tracking rubber and PP; • castor diameter: 125 mm • 2 fixed castors • 2 swivelling castors, of which 1 with brake. 		<p>Monobloc structure, no sharp edges, joints and welds.</p>
	<p>Stainless steel interlocking kit available to interlock two stacked containers (modular system).</p>		<p>Insulated with CFC and HCFC-free polyurethane foam.</p>
<p>K</p>	<p>Overall heat transmission coefficient: K=0,48 W/m2K.</p>		

TECHNICAL SPECIFICATIONS

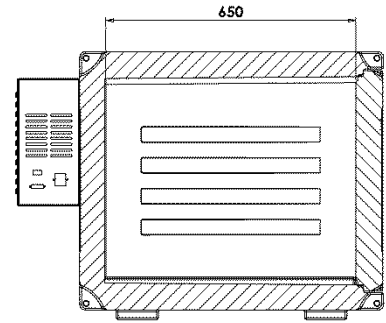
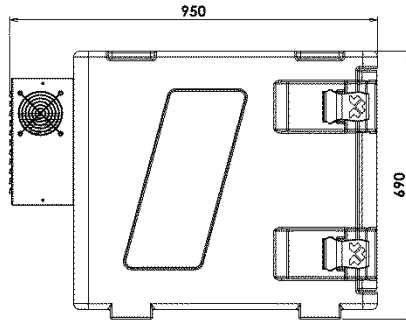
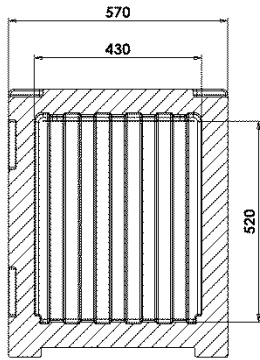

**Modello frigo dorso statico 0°C +10/+40°C
Cod.: A1509006, A1509040**

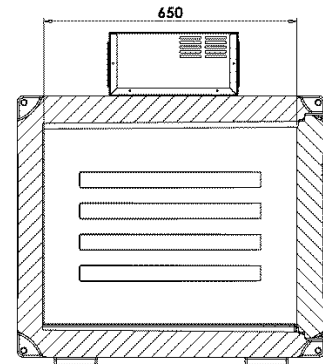
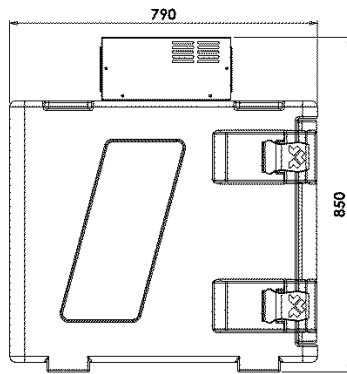
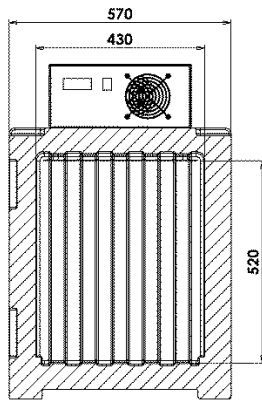

**Model with coling unit on top static 0°C +10/+40°C
code: A1509034, A1509067**

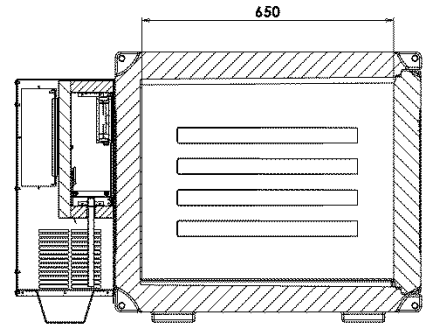
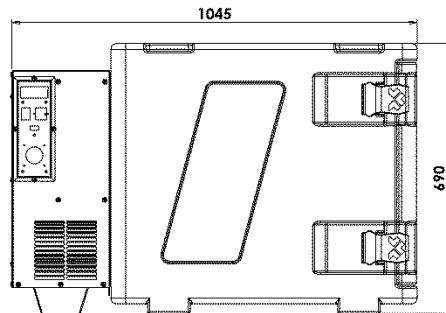
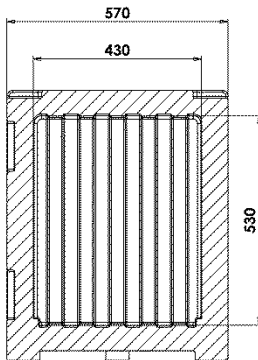

**Model with cooling unit on back ventilated 0°C +10/+40°C
code: A1509043, A1509068**

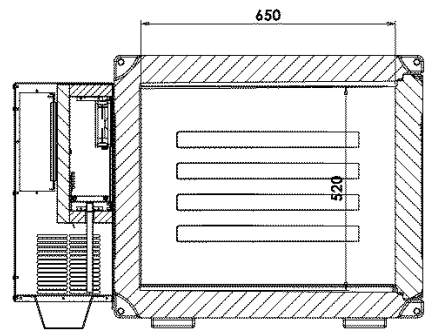
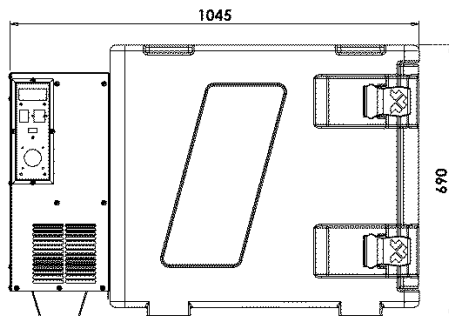
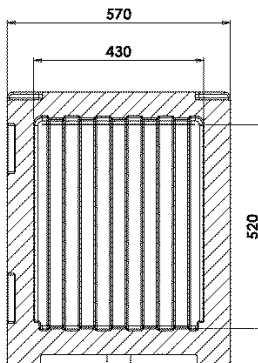

**Model with cooling unit on back static -18/-25°C +10/+40°C
code: A1509037, A1509065, A1509066, A1509062**

Model	Code	12V Power supply Fork terminal	12/24 V Power supply Cigarette lighter socket	Nominal absorption	Fuses
AF VERSION					
Koala 150 AF cooling unit on back static from 0°C to +10°C	A1509006		✓	0,35A to 230Vac 3,5A to 24Vdc 7A to 12Vdc	4A for 230Vac 15A for 12/24Vdc
Koala 150 AF cooling unit on top static from 0°C to +10°C	A1509034		✓	0,35A to 230Vac 3,5A to 24Vdc 7A to 12Vdc	4A for 230Vac 15A for 12/24Vdc
Koala 150 AF cooling unit on back ventilated from 0°C to +10°C	A1509043	✓		0,62A to 230Vac 12A to 12Vdc	4A for 230Vac 25A for 12Vdc
Koala 150 AF cooling unit on back static from -18°C to +10°C	A1509037	✓		1A to 230Vac 18A to 12Vdc	4A for 230Vac 30A for 12Vdc
Koala 150 AF cooling unit on back static from -25°C to +10°C	A1509065	✓		1A to 230Vac 18A to 12Vdc	4A for 230Vac 30A for 12Vdc
AFH VERSION (with heating kit)					
Koala 150 AFH cooling unit on back static from 0°C to +40°C	A1509040		✓	0,35A to 230Vac 7A to 12Vdc	4A for 230Vac 15A for 12Vdc
Koala 150 AFH cooling unit on top static from 0°C to +40°C	A1509067		✓	0,35A to 230Vac 7A to 12Vdc	4A for 230Vac 15A for 12Vdc
Koala 150 AFH cooling unit on back ventilated from 0°C to +40°	A1509068	✓		0,62A to 230Vac 12A to 12Vdc	4A for 230Vac 25A for 12Vdc
Koala 150 AFH cooling unit on back static from -18°C to 40°C	A1509066	✓		1A to 230Vac 18A to 12V dc	4A for 230Vac 30A for 12V dc
Koala 150 AF cooling unit on back static from -25°C to +40°C	A1509062	✓		1A to 230Vac 18A to 12V dc	4A for 230Vac 30A for 12V dc

Model	Code	Colour	External dim. (mm)	Internal dim. (mm)	Capacity l	Weight Kg
Koala 150 AF/AFH cooling unit on back static 0°C +10/+40°C	A1509006 A1509040	melange grey blue	570x950xh690	430x650xh520	148	37
Koala 150 AF/AFH cooling unit on top static 0°C +10/+40°C	A1509034 A1509067	melange grey blue	570x790xh850	430x650xh520	148	37
Koala 150 AF/AFH cooling unit on back ventilated 0°C +10/+40°C	A1509043 A1509068	melange grey blue	570x1045xh690	430x650xh530	148	55
Koala 150 AF/AFH cooling unit on back static -18/-25°C +10/+40°C	A1509037 A1509065 A1509066 A1509062	melange grey blue	570x1045xh690	430x650xh520	148	55
ACCESSORIES						
Set of brackets for runners	ABA250	stainless steel				2,5
Pair of runners	ABA302	stainless steel				1,2
Grid in stainless steel	AEA020	stainless steel	530x325xh12			1,3
Self-supporting grid in stainless steel	AEA012	stainless steel	430x630xh262			3
Trolley in polyethylene (for A1509006, A1509034, A1509040, A1509067)	THS30006	melange grey blue	625x845xh210			6,3
Single interlocking kit - 2 pieces -	RRI139	stainless steel	2 pezzi per kit			0,6
Label holder A5 dimensions	AMC106	transparent	242xh157	148xh210 -A5-		

