

Typical Counter Installation
HCRU2 with Size 2 Drop In unit

Important Design Parameters
Allow a minimum air space of 15mm all round for easy slide in under counter.

Warning
Ideally the electrical socket fitted in the counter would be recessed
Be aware allowances must be made for any protruding power outlets etc.

Also suitable for a counter set at 850mm high

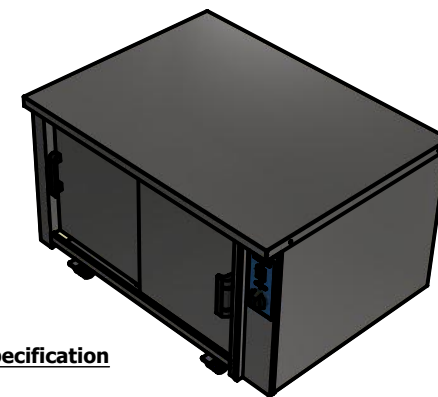
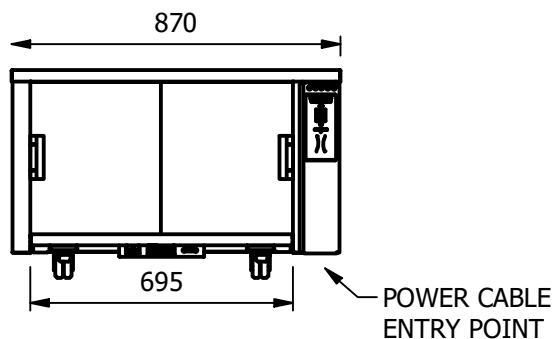
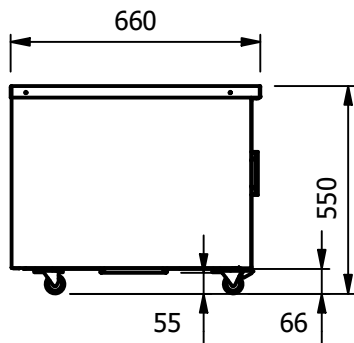
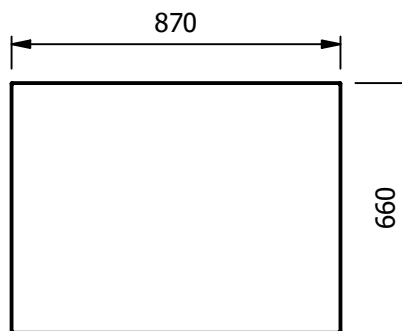

Versigen Specification

Dry Heat
Fan Assisted Hotcupboard



Sahara Fan Model SF309

Dimensions
Width - 870mm
Depth - 660mm
Height - 550mm
Weight - 34kg

Capacity [usable inside space]
Width - 695mm
Depth - 545mm
Height - 306mm

Power Rating
0.9kw
complete with a 2m long cord set & 10amp plug
Removable Fan heating System Sahara Fan Model SF309

Materials
1.2mm 304 Grade St/ Steel Top & Supports
0.7mm 430 Grade St/ Steel Internal Structure
GN 1/1 Grid Shelves with 30mm x 30mm tube supports

Installation
RollUnder
All swivel castors, two braked

Minimum Under Counter Void Space
Dimensions
Width - 900mm
Depth - 675mm
Height - 565mm

ALL SHEET METAL DIMENSIONS ARE I/S (INSIDE SIZES) (UNLESS OTHERWISE STATED)

ALL DIMENSIONS IN (mm), TOLERANCE = LINEAR ± 0.5mm, ANGULAR ± 0.5mm (OR AS STATED). ALL SHARP EDGES TO BE REMOVED FROM SHEET METAL PARTS

Product	ROLL UNDER HOTCUPBOARD			Product No	N/A	<p>No reproduction or publication of this drawing may be made, and no article may be manufactured or assembled in accordance with this drawing without prior written consent. This prohibition is a term of any contract relating to this drawing. Rights reserved under the Copyright Act 1956 as amended by the Design Copyright Act 1968.</p>	<p>FOODSERVICE EQUIPMENT</p>		
Description	HC2RU								
Material/Finish	Thickness		Desp/Date			Dwg No.	CTRP-078451	Issue	
Legacy P/N	Weight	34kg	Quote No.			Drawn By	ABB	-	
Client			SO Number	STD		Date	13/08/2019		
Client Project			Approved By			Scale	1 : 20	Sheet	
VERSIGEN AUSTRALIA PTY LTD, 182 HARTLEY ROAD, SMEATON GRANGE, NSW 2567, T: +61 (0)131 653 330, E: sales@versigen.com.au, Web: www.versigen.com.au								1 / 2	A4